

1
2
3
4
5
6
7
8
9
10
11
12
13
14
15
16
17
18
19
20
21
22
23
24

UNITED STATES DISTRICT COURT
WESTERN DISTRICT OF WASHINGTON
AT SEATTLE

DONGGUAN ZHOUDA TECHNOLOGY
CO. LTD. et al.,

Plaintiffs,

v.

XINJIE DAI,

Defendant.

CASE NO. 2:25-cv-00536-TL

ORDER ON SECOND MOTION FOR
TEMPORARY RESTRAINING
ORDER

This matter is before the Court on Plaintiffs’ Second Motion for Temporary Restraining Order. Dkt. No. 20. Having considered Plaintiffs’ motion and the relevant record, the Court GRANTS IN PART and DENIES IN PART Plaintiffs’ motion.

I. BACKGROUND

Having recently summarized the facts and history of this case, the Court assumes familiarity with the background and only sets out relevant developments below. *See* Dkt. No. 17 at 1–2.

1 On May 15, 2025, Plaintiffs filed a motion for an *ex parte* temporary restraining order
2 (“TRO”). Dkt. No. 9. The Court denied Plaintiffs’ motion, determining that it could not grant the
3 motion “without a certification of adequate notice to Defendant or a basis for issuing an *ex parte*
4 TRO before Defendant can be heard.” Dkt. No. 17 at 4 (citing *Kovalenko v. Epik Holdings Inc.*,
5 No. C22-1578, 2022 WL 16737471, at *2 (W.D. Wash. Nov. 7, 2022)). The Court also noted
6 that “Plaintiffs waited nearly two months after the filing of their original complaint to move for a
7 TRO, further demonstrating that the injury alleged is not so immediate as to justify an *ex parte*
8 TRO.” *Id.* at 5.

9 Following the issuance of the Court’s Order, Plaintiffs moved for electronic service of
10 process; this motion remains pending. Dkt. No. 18. Plaintiffs now move again for an *ex parte*
11 TRO. Dkt. No. 20.

12 II. LEGAL STANDARD

13 “A TRO, as with any preliminary injunctive relief, is an extraordinary remedy that is
14 ‘never awarded as of right.’” *Kovalenko*, 2022 WL 16737471, at *2 (citing *Winter v. Nat. Res.*
15 *Def. Council, Inc.*, 555 U.S. 7, 24 (2008)). The standards that govern TROs are “substantially
16 similar” to those that govern preliminary injunctions. *Holthouse v. Wash. Dep’t of Corr.*, No.
17 C25-5257, 2025 WL 1167659, at *1 (W.D. Wash. Apr. 22, 2025) (citing *Washington v. Trump*,
18 847 F.3d 1151, 1159 n.3 (9th Cir. 2017)). “To obtain a preliminary injunction, a plaintiff must
19 establish: (1) a likelihood of success on the merits, (2) a likelihood of irreparable harm in the
20 absence of preliminary relief, (3) that the balance of equities favors the plaintiff, and (4) that an
21 injunction is in the public interest.” *Id.* (quoting *Geo Group, Inc. v. Newsom*, 50 F.4th 745, 753
22 (9th Cir. 2022) (en banc)). This test, arising from *Winter*, requires that the movant establish each
23 element. *See id.*

1 A preliminary injunction (and, by extension, a TRO) “may only be awarded ‘upon a clear
2 showing’ of evidence that supports each relevant preliminary injunction factor.” *Medcursor Inc.*
3 *v. Shenzhen KLM Internet Trading Co., Ltd.*, 543 F. Supp. 3d 866, 870 (C.D. Cal. 2021) (quoting
4 *Winter*, 555 U.S. at 22). “This ‘clear showing’ requires factual support beyond the allegations of
5 the complaint, but the evidence need not strictly comply with the Federal Rules of Evidence.” *Id.*
6 (quoting *CI Games S.A. v. Destination Films*, No. C16-5719, 2016 WL 9185391, at *11 (C.D.
7 Cal. Oct. 25, 2016) (citing *Flynt Distrib. Co., Inc. v. Harvey*, 734 F.2d 1389, 1394 (9th Cir.
8 1984))).

9 “Granting injunctive relief is ‘an act of equitable discretion’ on the part of the District
10 Court.” *BitTitan, Inc. v. SkyKick, Inc.*, No. C15-754, 2015 WL 5081130, at *2 (W.D. Wash. Aug.
11 27, 2015) (quoting *eBay, Inc. v. MercExchange, LLC*, 547 U.S. 388, 391 (2006)). “As such, no
12 one factor is necessarily dispositive, but ‘the absence of an adequate showing with regard to any
13 one factor may be sufficient, given the weight or lack of it assigned the other factors, to justify
14 denying the motion.’” *Id.* (quoting *Chrysler Motors Corp. v. Auto Body Panels of Ohio, Inc.*, 908
15 F.2d 951, 953 (Fed. Cir. 1990)). The Ninth Circuit utilizes a “sliding scale approach,” under
16 which “a stronger showing of one element may offset a weaker showing of another, as long as
17 plaintiffs ‘establish that irreparable harm is likely.’” *Doe v. Kelly*, 878 F.3d 710, 719 (9th Cir.
18 2017) (quoting *All. for the Wild Rockies v. Cottrell*, 632 F.3d 1127, 1134–35 (9th Cir. 2011)); *see*
19 *also Where Do We Go Berkeley v. Cal. Dep’t of Transp.*, 32 F.4th 852, 859 (9th Cir. 2022) (“We
20 employ a ‘sliding scale test,’ which allows a strong showing on the balance of hardships to
21 compensate for a lesser showing of likelihood of success.” (quoting *All. for the Wild Rockies*,
22 632 F.3d at 1134–35)).

23 “Importantly, given that the U.S. federal jurisprudence ‘runs counter to the notion of
24 court action taken before reasonable notice and an opportunity to be heard has been granted both

1 sides of a dispute . . . , courts have recognized very few circumstances justifying the issuance of
2 an *ex parte* TRO.” *Kovalenko*, 2022 WL 16737471, at *2 (omission in original) (quoting *Reno*
3 *Air Racing Ass’n v. McCord*, 452 F.3d 1126, 1131 (9th Cir. 2006)). In line with this principle,
4 Federal Rule of Civil Procedure 65(b) provides the following:

5 (a)(1) **Notice**. The court may issue a preliminary injunction only on
6 notice to the adverse party.

7

8 (b)(1) **Issuing Without Notice**. The court may issue a temporary
9 restraining order without written or oral notice to the adverse party
10 or its attorney only if:

11 (A) specific facts in an affidavit or a verified complaint clearly
12 show that immediate and irreparable injury, loss, or damage will
13 result to the movant *before* the adverse party can be heard in
14 opposition; and

15 (B) the movant’s attorney certifies in writing any efforts made to
16 give notice and the reasons why it should not be required.

17 (emphases added). Further, Local Civil Rule 65 provides:

18 Motions for temporary restraining orders without notice to and an
19 opportunity to be heard by the adverse party are disfavored and
20 will rarely be granted. Unless the requirements of Fed. R. Civ. P.
21 65(b) for issuance without notice are satisfied, the moving party
22 must serve all motion papers on the opposing party, by electronic
23 means if available, before or contemporaneously with the filing of
24 the motion *and include a certificate of service with the motion. The
motion must also include contact information for the opposing
party’s counsel or for an unrepresented party.*

LCR 65(b)(1) (emphasis added).

III. DISCUSSION

A. Applying the Temporary Restraining Order to Non-Party Conduct

As an initial matter, the Court discusses Plaintiffs’ proposed temporary restraining order,
which seeks to restrain the actions of actors *other* than Defendant. Plaintiffs’ proposed order, in

1 part, directs “[a]ny online marketplace platforms including, without limitation, Amazon, eBay,
2 Wish, AliExpress, Joom, Vova, Temu, Walmart” to “retract, withdraw, or void the complaint and
3 reinstate any products listings affected thereby.” Dkt. No. 20-1 at 2. But online marketplace
4 platforms like Amazon are not parties to the instant matter.

5 Pursuant to Federal Rule of Civil Procedure 65, a court may order injunctive relief that
6 “binds only . . . (A) the parties; (B) the parties’ officers, agents, servants, employees, and
7 attorneys; and (C) other persons who are in active concert or participation with anyone
8 described” in subsections (A) and (B). Fed. R. Civ. P. 65(d)(2); *see also Whole Woman’s Health*
9 *v. Jackson*, 595 U.S. 30, 44 (2021) (“[U]nder traditional equitable principles, no court may
10 lawfully enjoin the world at large[.]”) (cleaned up)). “For an injunction to bind a non-party, the
11 movant must show that (1) the non-party has actual notice of the enjoined conduct and (2) either
12 aided and abetted the enjoined party in the unlawful conduct or that the non-party is ‘legally
13 identified’ with the enjoined party.” *Patagonia, Inc. v. Frances Agnew DBA Fran Calista*,
14 No. C25-3283, 2025 WL 1617182, at *11 (C.D. Cal. June 5, 2025) (citing *Consumer Fin. Prot.*
15 *Bureau v. Howard L., P.C.*, 671 F. App’x 954, 955 (9th Cir. 2016)). While non-parties are often
16 enjoined in patent or trademark cases, courts have narrowed the scope of requested injunctions
17 where the moving party does not sufficiently establish a connection between the non-party and
18 the challenged conduct. *See id.*

19 For example, in *cPanel, LLC v. Asli*, a trademark infringement case concerning the
20 “cPanel license,” the court declined to issue an injunction to non-party service providers where
21 plaintiffs had failed to allege that those providers were in privity with defendants. 719 F. Supp.
22 3d 1133, 1154 (D. Or. 2024). The court noted that “[w]hen privity is invoked as a basis for
23 binding a nonparty to an injunction, it is ‘restricted to persons so identified in interest with those
24 named in the decree that it would be reasonable to conclude that their rights and interests have

1 been represented and adjudicated in the original injunction proceeding,” and determined that
2 plaintiffs had not explained how the non-parties’ interests had been adequately represented by
3 defendant. *Id.* at 1154–55. Additionally, the *cPanel* court found that plaintiffs had not adequately
4 addressed aiding and abetting under Rule 65(d), which requires that for an injunction to bind a
5 non-party, that non-party must “know that its conduct is highly likely to cause a violation of an
6 injunction.” *Id.* at 1155 (cleaned up) (quoting *Inst. of Cetacean Rsch. v. Sea Shepherd Conserv.*
7 *Soc’y*, 774 F.3d 935, 951 (9th Cir. 2014)).

8 Here, Plaintiffs have made no argument as to the notice of any non-party to Defendant’s
9 allegedly unlawful activities, and none of the non-parties named in Plaintiffs’ proposed
10 injunction has appeared in this action. *See generally* Dkt. No. 20. Accordingly, the Court cannot
11 find that any of the named non-parties has been provided notice or an opportunity to litigate its
12 rights before this Court. Further, Plaintiffs have failed to allege that any of the named non-parties
13 is legally identified with Defendant or aided and abetted Defendant in the allegedly unlawful
14 conduct. *See generally id.*

15 Accordingly, the Court DENIES Plaintiffs’ request to issue a temporary restraining order
16 against the non-named parties in its proposed order. *See* Dkt. No. 20-1 at ¶ 2.

17 **B. Likelihood of Success on the Merits**

18 In their complaint, Plaintiffs assert claims for Declaratory Judgment of Invalidity, Unfair
19 Business Practices, and Tortious Interference with Prospective Economic Advantage. *See* Dkt.
20 No. 7. These claims all arise from Defendant’s patent infringement complaints to Amazon.com
21 (“Amazon”) against Plaintiffs based on Defendant’s January 7, 2025, patent for “[t]he
22 ornamental design for a tumbler lid,” U.S. Patent No. D1,056,616 (the “’616 Patent”), which
23 caused Amazon to effect the deactivation of products that Plaintiffs were selling. *Id.* ¶¶ 21–28;
24 Dkt. No. 7-1 (design patent) at 2; *see also* Dkt. Nos. 7-2–7-5 (infringement complaints).

1 Design patents are presumed to be valid. 35 U.S.C. § 282(a). *BitTitan*, 2015 WL
2 5081130, at *3 (citing 35 U.S.C. § 282(a)) (“[A]n assumed patent is presumed valid, both as a
3 whole and on a claim-by-claim basis[.]”). “[P]atent[s] enjoy[] the same presumption of validity
4 during preliminary injunction proceedings as at other stages of litigation.” *Titan Tire Corp. v.*
5 *Case New Holland, Inc.*, 566 F.3d 1372, 1377 (Fed. Cir. 2009). The Court “does not resolve the
6 validity question” at this stage, but instead “assess[es] . . . the persuasiveness of the challenger's
7 evidence,” recognizing that it is a preliminary stage. *Id.* It is Plaintiffs’ burden to “identify any
8 persuasive evidence of invalidity.” *Purdue Pharma L.P. v. Boehringer Ingelheim GMBH*, 237
9 F.3d 1359, 1365 (Fed. Cir. 2001). However, “[b]ecause ‘vulnerability is the issue at the . . .
10 injunction stage,’ a showing of a substantial question of invalidity ‘requires less proof than the
11 clear and convincing showing necessary to establish invalidity itself.’” *Amazon, Inc. v.*
12 *Barnesandnoble.com, Inc.*, 239 F.3d 1343, 1359 (Fed. Cir. 2001).

13 Plaintiffs argue here that the ’616 Patent is invalid as anticipated under 35 U.S.C. § 102.
14 Dkt. No. 20 at 4; *see also* Dkt. No. 7 ¶ 40.

15 “Patents, whether for a design or otherwise, must be unanticipated as required by 35
16 U.S.C. § 102.” *Laughing Rabbit, Inc. v. Nat’l Auto. Parts Ass’n*, No. C12-402, 2014 WL 556007,
17 at *5 (W.D. Wash. Feb. 11, 2014). Patent claims are invalid as anticipated if “the claimed
18 invention was patented, described in a printed publication, or in public use, on sale, or otherwise
19 available to the public before the effective filing date of the claimed invention.” 35 U.S.C.
20 § 102(a)(1). Thus, in challenging a patent’s validity, “design patent anticipation requires a
21 showing that a single prior art reference is identical in all material respects to the claimed
22 invention.” *Medcursor*, 543 F. Supp. 3d at 871.

23 “In comparing design patent prior art with the claimed design to determine if the prior art
24 is invalidating, the Federal Circuit has explained that ‘the ordinary observer test must logically

1 be the sole test for [design patent] anticipation.” *Id.* (quoting *Int’l Seaway Trading Corp. v.*
2 *Walgreens Corp.*, 589 F.3d 1233, 1240 (Fed. Cir. 2009)). “That test asks whether, ‘in the eye of
3 an ordinary observer, giving such attention as a purchaser usually gives, two designs are
4 substantially the same.” *Id.* (quoting *Egyptian Goddess, Inc. v. Swisa, Inc.*, 543 F.3d 665, 670
5 (Fed. Cir. 2008)). “Designs are substantially the same when ‘the resemblance is such as to
6 deceive the ordinary observer, inducing him to purchase one supposing it to be the other.” *Id.*
7 (quoting *Egyptian Goddess*, 543 F.3d at 670). An examiner’s analysis “may include recourse to
8 logic, judgment, and common sense available to a person of ordinary skill that do not necessarily
9 require explication in any reference or expert opinion.” *Perfect Web Techs. v. InfoUSA, Inc.*, 587
10 F.3d 1324, 1329 (Fed. Cir. 2009). “In these cases the examiner should at least explain the logic
11 or common sense that leads the examiner to believe the claim would have been obvious.” *In re*
12 *Vaidyanathan*, 381 F. App’x 985, 994 (Fed. Cir. 2010) (citing *In re Zurko*, 258 F.3d 1379, 1386
13 (Fed. Cir. 2001)).

14 To make this determination, courts generally engage in a side-by-side comparison of
15 various views of the patented designs. The Federal Circuit has emphasized the importance of
16 considering various views of the designs: in *Apple, Inc. v. Samsung Elecs. Co., Ltd.*, 678 F.3d
17 1314, 1326 (Fed. Cir. 2012), it overturned a district court determination that a patent was likely
18 anticipated where the decision had been solely based on a single view of the product design
19 image. In determining whether a D’087 patent had been anticipated by a Japanese ’638 patent,
20 the district court had “based its ruling on its conclusion that ‘the front view of the D’087 patent
21 appears to be substantially similar to the front view of the ’638 reference,’” but “refused to
22 consider any other views of the ’638 reference because it found that [plaintiff] ‘never claimed all
23 views of the ’638 patent.” *Id.*; *see also id.* at 1319. The Federal Circuit found that this was error
24 and went on to compare images of the two patents, finding that “[w]hen the claimed portion of

1 the side view is taken into account, the differences between the arched, convex front of the '638
2 reference distinguish it from the perfectly flat front face of the D'087 patent.” *Id.* at 1326.

3 In *Medcursor*, the court noted that plaintiff initially “failed to demonstrate anticipation by
4 comparing the prior art Yinghao Solar design to all claimed views of the patented design, as
5 depicted in the drawings.” 543 F. Supp. 3d at 871. In supplemental briefing on the request for an
6 injunction, plaintiff remedied its deficiency by providing “additional images and a supplemental
7 declaration from Qiang Zhuo, who [p]laintiff aver[red] is the true design inventor. Using those
8 images, [p]laintiff provide[d] a side-by-side comparison to support likelihood of success on the
9 merits that the designs are the same and therefore the prior art is invalidating.” *Id.* at 871–72.

10 Plaintiffs argue here that “[t]he invention claimed in the '616 Patent is anticipated by at
11 least one prior art reference”—EU Design Registration No 015062918-0001 (the “Prior Art
12 Design”). Dkt. No. 20 at 4. Plaintiffs contend that the Prior Art Design, registered on July 6,
13 2024, is “identical” to Defendant’s '616 Patent, and that “an ordinary observer would very likely
14 recognize that the design of the '616 Patent is ‘substantially the same’ as the Prior Art Design.”
15 *Id.* Plaintiffs offer several comparisons between the '616 Patent and Prior Art Design and argue
16 that “it is apparent that Defendant attempted to obfuscate the similarities” between the compared
17 images by repositioning the product in the designs. *Id.* at 4–5. The Court addresses each
18 comparison in turn:

1 **1. Figure 1**



8
9 Prior Art Design Fig. 0001.7

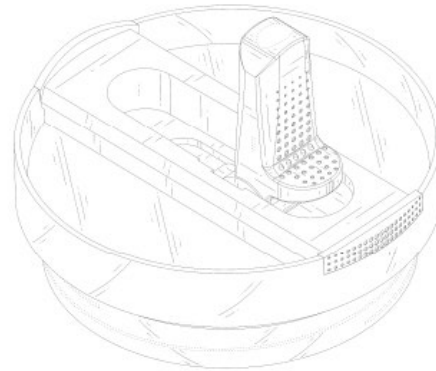

10 '616 Design Fig. 1

11
12 Dkt. No. 9-2 at 2. Plaintiffs contend that Defendant intentionally obfuscates similarities in this
13 image by “showing a reverse side of the top front perspective view of the lid where the straw
14 structure is extended, showing the “back” part of the straw structure and not the front.” Dkt. No.
15 20 at 4 (citing Dkt. No. 9-2 at 2).

16 These two images both show a tumbler lid assembly with an extendable straw structure
17 housed in a center component on the lid assembly. Additionally, both images show gripping on
18 the “back” part of the straw structure and the visible end of the center component on the lid
19 assembly. Both images appear to show a rim running along the outer edge of the upper assembly.
20 Both images appear to show threading on the bottom portion of the lid assembly (though it is
21 more pronounced in the Prior Art Design¹). Considering the positioning and perspective in light

22
23 ¹ The '616 Patent disclaims this threading element, as the lower threaded portion of the lid top is depicted in broken
24 lines. Dkt. No. 7-1 at 2 (“The broken lines in the drawings illustrate the portions of the tumbler lid, which form no
part of the claimed design.”); see *In re Owens*, 710 F.3d 1362, 1367 n.1 (Fed. Cir. 2013) (“[i]n initial design

1 of the lower level of proof required at the injunction stage, the Court finds that Plaintiffs can
 2 likely succeed in showing that, in the eye of an ordinary observer, giving such attention as a
 3 purchaser usually gives, these images of the '616 Patent and Prior Art Design show a product
 4 that is substantially the same.

5 **2. Figure 2**

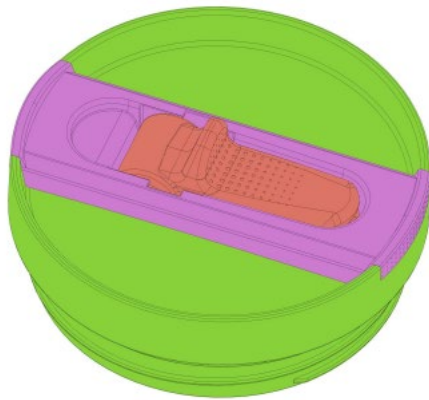

12 Prior Art Design Fig. 0001.6

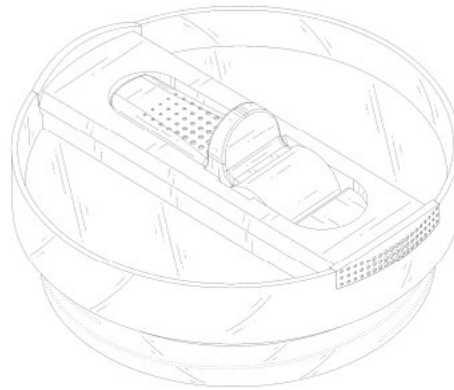

14 '616 Patent Fig. 9

15 Dkt. No. 9-2 at 3. Plaintiffs contend that Defendant intentionally obfuscates similarities in this
 16 image by “showing a reverse side of the other top front perspective view of the lid where the
 17 straw structure is collapsed, showing the “back” part of the straw structure and not the front.”

18 Dkt. No. 20 at 4 (citing Dkt. No. 9-2 at 3).

19 These two images both show a tumbler lid assembly with an extendable straw structure
 20 housed in a center component on the lid assembly. Additionally, both images show gripping on
 21 the “back” part of the straw structure and the visible end of the center component on the lid
 22 assembly. Both images appear to show a rim running along the outer edge of the upper assembly.
 23 Both images appear to show threading on the bottom portion of the lid assembly (though it is

24 _____
 applications, it is appropriate to disclaim certain design elements using broken lines, provided the application makes
 clear what has been claimed.”).

1 more pronounced in the Prior Art Design).² Considering the positioning and perspective in light
 2 of the lower level of proof required at the injunction stage, the Court finds that Plaintiffs can
 3 likely succeed in showing that, in the eye of an ordinary observer, giving such attention as a
 4 purchaser usually gives, these images of the '616 Patent and Prior Art Design show a product
 5 that is substantially the same.

6 **3. Figure 3**

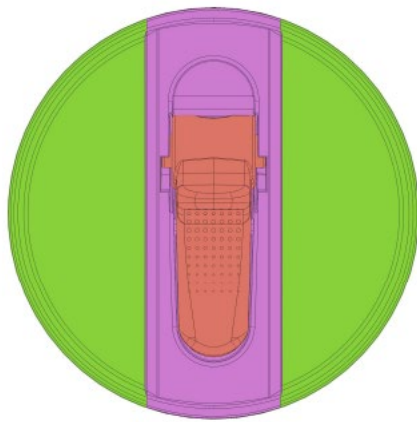

13 Prior Art Design Fig. 0001.5



15 '616 Patent Fig. 7 (flipped vertically)

16 Dkt. No. 9-2 at 4. Plaintiffs contend that Defendant intentionally obfuscates similarities in this
 17 image by “illustrating the top view where the straw structure was extended, rather than collapsed
 18 as shown in the Prior Art Design.” Dkt. No. 20 at 4 (citing Dkt. No. 9-2 at 4).

19 These two images both show a tumbler lid assembly with an extendable straw structure
 20 housed in a center component on the lid assembly. Additionally, both images show gripping on
 21 the “back” part of the straw structure. Both images appear to show a rim running along the outer
 22 edge of the assembly. Both images also appear to show a straw that is rounded on one end.

23 Considering the positioning and perspective in light of the lower level of proof required at the

24 ² See *supra* n.1.

1 injunction stage, the Court finds that Plaintiffs can likely succeed in showing that, in the eye of
 2 an ordinary observer, giving such attention as a purchaser usually gives, these images of the '616
 3 Patent and Prior Art Design show a product that is substantially the same.

4 **4. Figure 4**

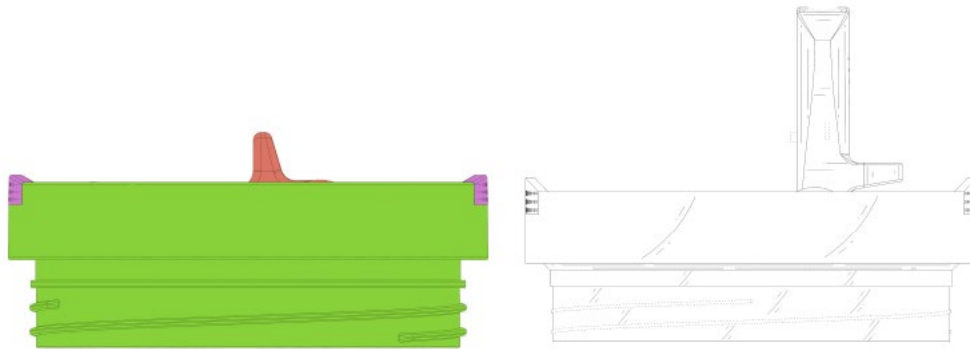

5
6
7
8
9
10
11
12 Prior Art Design Fig. 0001.4

'616 Patent Fig. 5

13
14 Dkt. No. 9-2 at 5. Plaintiffs contend that Defendant intentionally obfuscates similarities in this
 15 image by “showing the left side view of the lid with the straw structure extended, rather than
 16 collapsed as shown in the Prior Art Design.” Dkt. No. 20 at 4 (citing Dkt. No. 9-2 at 5).

17 These two images both show a tumbler lid assembly with an extendable straw structure
 18 housed in a center component on the lid assembly. Both images appear to show a rim running
 19 along the outer edge of the assembly, with a slightly more pronounced rim on both ends of the
 20 straw structure. Both images appear to show threading on the bottom portion of the lid assembly
 21 (though it is more pronounced in the Prior Art Design).³ The Prior Art Design also appears to
 22 contain a rim underneath the upper assembly, above the threading, while the '616 Patent shows a
 23

24 ³ See *supra* n.1.

1 rim where the upper and lower assembly connect; however, this difference does not appear to be
 2 so great as to confuse an ordinary observer. Considering the positioning and perspective in light
 3 of the lower level of proof required at the injunction stage, the Court finds that Plaintiffs can
 4 likely succeed in showing that, in the eye of an ordinary observer, giving such attention as a
 5 purchaser usually gives, these images of the '616 Patent and Prior Art Design show a product
 6 that is substantially the same.

7 **5. Figure 5**

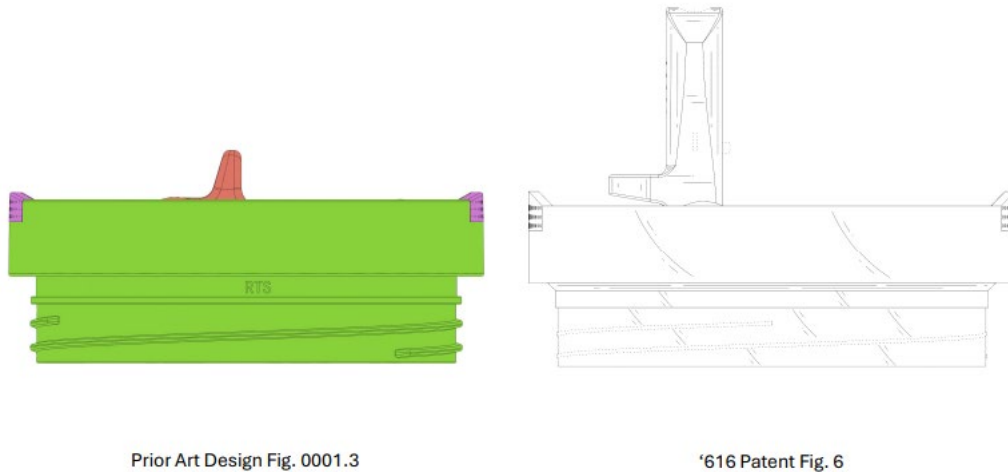

15

16

17 Dkt. No. 9-2 at 6. Plaintiffs contend that Defendant intentionally obfuscates similarities in this
 18 image by “showing the right side view of the lid with the straw structure extended, rather than
 19 collapsed as shown in the Prior Art Design.” Dkt. No. 20 at 4 (citing Dkt. No. 9-2 at 6).

20 These two images both show a tumbler lid assembly with an extendable straw structure
 21 housed in a center component on the lid assembly. Both images appear to show a rim running
 22 along the outer edge of the assembly, with a slightly more pronounced rim on both ends of the
 23 straw structure. Both images appear to show threading on the bottom portion of the lid assembly

(though it is more pronounced in the Prior Art Design).⁴ The Prior Art Design also appears to contain a rim underneath the upper assembly, above the threading, while the '616 Patent shows a rim where the upper and lower assembly connect; however, this difference does not appear to be so great as to confuse an ordinary observer. Considering the positioning and perspective in light of the lower level of proof required at the injunction stage, the Court finds that Plaintiffs can likely succeed in showing that, in the eye of an ordinary observer, giving such attention as a purchaser usually gives, these images of the '616 Patent and Prior Art Design show a product that is substantially the same.

6. Figure 6



Dkt. No. 9-2 at 7. Plaintiffs contend that Defendant intentionally obfuscates similarities in this image by “showing the front view of the lid with the straw structure extended, rather than collapsed as shown in the Prior Art Design.” Dkt. No. 20 at 4 (citing Dkt. No. 9-2 at 7).

⁴ See *supra* n.1.

1 These two images both show a tumbler lid assembly with an extendable straw structure
2 housed in a center component on the lid assembly. The '616 Patent shows gripping on the “back”
3 part of the straw structure and the visible end of the center component on the lid assembly,
4 whereas the Prior Art Design only shows gripping on the visible end of the center component.
5 However, this discrepancy comports with Plaintiffs’ alleged obfuscation because the '616 Patent
6 shows the front view of the lid with the straw structure extended, rather than collapsed—based
7 on other perspectives of the Prior Art Design, it is apparent that the Prior Art Design also
8 includes gripping on the “back” part of the straw structure. *See supra* Section III.B.3 (citing Dkt.
9 No. 9-2 at 4). Both images appear to show threading on the bottom portion of the lid assembly
10 (though it is more pronounced in the Prior Art Design).⁵ The Prior Art Design also appears to
11 contain a rim underneath the upper assembly, above the threading, while the '616 Patent shows a
12 rim where the upper and lower assembly connect. Considering the positioning and perspective in
13 light of the lower level of proof required at the injunction stage, the Court finds that Plaintiffs
14 can likely succeed in showing that, in the eye of an ordinary observer, giving such attention as a
15 purchaser usually gives, these images of the '616 Patent and Prior Art Design show a product
16 that is substantially the same.

17
18
19
20
21
22
23
24

⁵ *See supra* n.1.

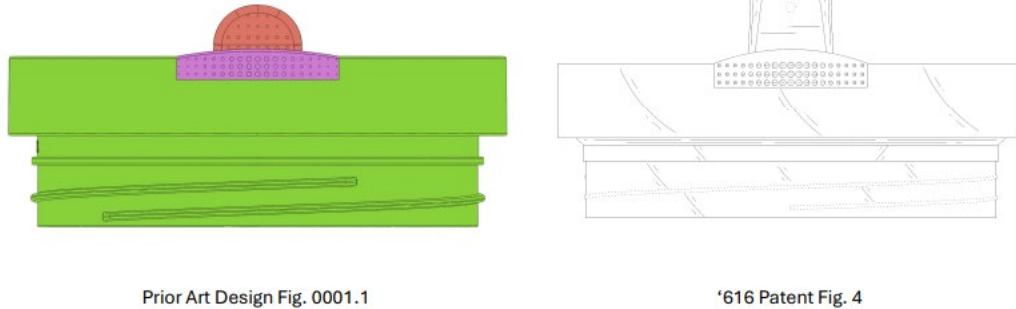
7. **Figure 7**

Dkt. No. 9-2 at 8. Plaintiffs contend that Defendant intentionally obfuscates similarities in this image by “showing the rear view of the lid with the straw structure extended, rather than collapsed as shown in the Prior Art Design.” Dkt. No. 20 at 4–5 (citing Dkt. No. 9-2 at 8).

These two images both show a tumbler lid assembly with an extendable straw structure housed in a center component on the lid assembly. The Prior Art Design shows gripping on the “back” part of the straw structure and the visible end of the center component on the lid assembly, whereas the '616 Patent only shows gripping on the visible end of the center component. However, this discrepancy comports with Plaintiffs’ alleged obfuscation because the '616 Patent shows the rear view of the lid with the straw structure extended, rather than collapsed—based on other perspectives of the Prior Art Design, it is apparent that the Prior Art Design also includes a straw structure without gripping on the “front” side of the straw. *See supra* Section III.B.1 (citing Dkt. No. 9-2 at 2). Both images appear to show threading on the bottom portion of the lid assembly (though it is more pronounced in the Prior Art Design).⁶ The

⁶ *See supra* n.1.

1 Prior Art Design also appears to contain a rim underneath the upper assembly, above the
2 threading, while the '616 Patent shows a rim where the upper and lower assembly connect;
3 however, this difference does not appear to be so great as to confuse an ordinary observer.
4 Considering the positioning and perspective in light of the lower level of proof required at the
5 injunction stage, the Court finds that Plaintiffs can likely succeed in showing that, in the eye of
6 an ordinary observer, giving such attention as a purchaser usually gives, these images of the '616
7 Patent and Prior Art Design show a product that is substantially the same.

8 * * *

9 Therefore, in light of the lower level of proof required at the injunction stage, the Court
10 finds that Plaintiffs can likely succeed in showing that, in the eye of an ordinary observer, giving
11 such attention as a purchaser usually gives, the '616 Patent and Prior Art Design are substantially
12 the same.

13 Plaintiffs have also offered factual support for the contention that the Prior Art Design
14 was available prior to the '616 Patent's filing date of July 31, 2024, as the patent for the Prior Art
15 Design was published on June 25, 2024. *See* Dkt. No. 20 at 5. *Compare* Dkt. No. 7-1 ('616
16 Patent design filed July 31, 2024), *with* Dkt. No. 9-3 (EU Intellectual Property Office Bulletin
17 2024/118 published June 25, 2024, where the Prior Art Design was published).

18 Accordingly, because Plaintiffs can likely succeed in showing that the '616 Patent's
19 design was previously patented, in public use, on sale, or otherwise available to the public prior
20 to the '616 Patent's effective filing date, they are likely to succeed on the merits of their first
21 claim for declaratory judgment of invalidity.

22 **C. Irreparable Harm**

23 "To obtain a preliminary injunction, the movant must also show that (1) absent an
24 injunction, it will suffer irreparable harm; and (2) a sufficiently strong causal nexus relates the

1 alleged harm to the alleged conduct.” *Medcursor*, 543 F. Supp. 3d at 877 (citing *Apple Inc. v.*
2 *Samsung Elecs. Co.*, 695 F.3d 1370, 1377–78 (Fed. Cir. 2012)). “The plaintiff must show more
3 than the ‘possibility’ of irreparable injury; he must demonstrate that irreparable injury is ‘likely’
4 and ‘imminent’ in the absence of preliminary relief.” *Id.* (quoting *Winter*, 555 U.S. at 22).
5 Relying heavily on *Medcursor*, Plaintiffs argue that their “intangible injuries like reputation,
6 advertising efforts, loss of potential customers, ranking and reviews, termination as a repeat
7 offender, or loss of goodwill constitutes irreparable harm.” Dkt. No. 20 at 5–6.

8 *Medcursor*, much like this case, concerned a declaratory relief action against defendants
9 who “filed a patent infringement report with Amazon, resulting in Amazon terminating
10 Plaintiff’s product listings for a solar-powered LED spotlight.” 543 F. Supp. 3d at 869. The court
11 determined that plaintiffs had raised two forms of concrete irreparable harm. *Id.* at 878.

12 First, the *Medcursor* plaintiff alleged that it sold its products almost exclusively on
13 Amazon, and that deactivation of its account would effectively put plaintiff out of business. *Id.*
14 “This is irreparable harm.” *Id.* (citing *Am. Trucking Ass’n, Inc. v. City of Los Angeles*, 559 F.3d
15 1046, 1058 (9th Cir. 2009) (finding irreparable harm where “it is likely that all of that part of the
16 carrier’s business will evaporate, even if it does other things elsewhere,” and “at the very least[,]
17 a loss of customer goodwill” will result based on inability to transact with customers at the
18 port)). Similarly, Plaintiffs here allege that they “sell their products substantially on
19 Amazon.com, and Plaintiffs’ inability to sell the products at issue would likely result in Plaintiffs
20 going out of business.” Dkt. No. 20 at 6.

21 Second, the *Medcursor* plaintiff also alleged, and the Court found, that its “product
22 delisting, if left unchecked, will likely result in nonquantifiable damages relating to lost business
23 opportunities on Amazon, including product placement disadvantages such as losing Plaintiff’s
24 previously held first-page status.” 543 F. Supp. 3d at 879. Plaintiffs in this case argue similarly

1 that their “ranking and product placement will likely continue to fall due to a lack of sales”
2 because they are no longer able to sell their de-listed products. Dkt. No. 20 at 10.

3 Plaintiffs also allege—and have submitted evidence establishing—that as a result of the
4 infringement complaints, their inventories of tumbler cup lids are scheduled to be disposed of
5 and destroyed on June 20, 2025. Dkt. Nos. 21–23. Plaintiffs argue that because Defendant is
6 based in China and has no domestic presence in the United States, “it will likely be impossible
7 for Plaintiffs to recover future monetary damages from Defendant to compensate them for the
8 value of the destroyed inventory.” Dkt. No. 20 at 7. All of this is sufficient to show irreparable
9 harm. *See Las Vegas Sands Corp. v. Fan Yu Ming*, 360 F. Supp. 3d 1072, 1080 (D. Nev. 2019)
10 (finding irreparable harm based upon plaintiff’s inability to recover a monetary judgment against
11 a foreign defendant with no presence in the United States); *Medcursor*, 543 F. Supp. 3d at 877–
12 79.

13 Therefore, Plaintiffs have shown that they are likely to suffer irreparable harm absent
14 extraordinarily relief. Additionally, because Plaintiffs have made a strong showing of irreparable
15 harm—specifically, the likelihood of their imminent loss of approximately \$150,000 worth of
16 inventory, the high possibility that they will be unable to recover monetary damages from
17 Defendant for any such loss, and their showing that the inability to sell the products at issue will
18 likely result in Plaintiffs going out of business (*see* Dkt. Nos. 21–23)—pursuant to the sliding
19 scale approach, this showing offsets any weakness in Plaintiffs’ showing of their likelihood of
20 success on the merits. *See Doe*, 878 F.3d at 719.

21 However, Plaintiffs’ proposed temporary restraining order, as written, cannot remedy this
22 irreparable harm. As discussed above, *see supra* Section III.A, Plaintiffs have not established
23 that the Court may apply the proposed temporary restraining order to non-parties to this action.
24 Accordingly, the Court will modify Plaintiffs’ proposed TRO to order *Defendant* to retract its

1 patent infringement notice filed with Amazon, in addition to enjoining Defendant from “issuing
2 takedown notices concerning [certain] Amazon Standard Identification Numbers (“ASINs”) and
3 products . . . , or otherwise notifying Amazon.com or other Third Party Platforms that Defendant
4 has patent rights being infringed by [certain] ASINs and products therein offered for sale,” as
5 requested. Dkt. No. 20-1 at 2; *see also Medcursor*, 543 F. Supp. 3d at 880 (granting injunction
6 requiring retraction of Amazon copyright takedown notices); *Beyond Blond Prods., LLC v.*
7 *Heldman*, 479 F. Supp. 3d 874, 890 (C.D. Cal. 2020) (same).

8 **D. Balancing of Harms**

9 In considering a TRO, “a court must balance the competing claims of injury and must
10 consider the effect on each party of the granting or withholding of the requested relief.” *Design*
11 *Furnishings, Inc. v. Zen Path, LLC*, No. C10-2765, 2010 WL 5418893, at *7 (E.D. Cal. Dec. 23,
12 2010) (quoting *Amoco Prod. Co. v. Vill. of Gambell, Alaska*, 480 U.S. 531, 542 (1987)).

13 Plaintiffs argue that the balancing of harms supports the entry of the TRO because the
14 injunctive relief sought is limited in scope and “restores the status quo by reversing Defendant’s
15 *de facto* injunction preventing sales of Plaintiffs’ products on Amazon.” Dkt. No. 20 at 11. The
16 Court agrees with Plaintiffs. As the court in *Medcursor* held:

17 Plaintiff seeks declaratory relief that the patent is invalid so that it
18 can continue to sell its products without fear of reprisal from
19 Defendants. Preserving the status quo would be allowing Plaintiff
20 to continue doing so during the pendency of this action. Again, to
the extent Plaintiff is wrong and Defendants prevail, damages for
infringing sales can be calculated easily.

21 543 F. Supp. 3d at 880. The same is true of Plaintiffs’ claims and sought relief here.

22 Given the likely irreparable harm identified above—particularly, the loss of Plaintiffs’
23 inventories of tumbler cup lids, which are scheduled to be disposed of and destroyed on June 20,
24 2025 (*see* Dkt. Nos. 21–23)—the balance of equities weighs in favor of ordering Defendant to

1 retract their patent infringement notice so that Plaintiffs’ products may be relisted and Plaintiffs’
2 Amazon accounts will not be suspended. *See Medcursor*, 543 F. Supp. 3d at 880. Like in
3 *Medcursor*, to the extent Defendant can prevail in proving the validity of the ’616 Patent, its
4 injuries “may be compensated by damages.”⁷ *Id.*

5 Therefore, the Court finds that the balance of equities tips in favor of a TRO.

6 **E. Public Interest**

7 “The public interest analysis for the issuance of a preliminary injunction requires [the
8 court] to consider ‘whether there exists some critical public interest that would be injured by the
9 grant of preliminary relief.’” *Design Furnishings*, 2010 WL 5418893, at *8 (quoting *Indep.*
10 *Living Ctr. of S. Cal., Inc. v. Maxwell–Jolly*, 572 F.3d 644, 659 (9th Cir. 2009), *overruled on*
11 *other grounds by Douglas v. Indep. Living Ctr. of S. Cal., Inc.*, 565 U.S. 606 (2012)).

12 Plaintiffs argue that “the public interest would be served by quelling Defendant’s
13 nonsensical infringement complaint to discriminately [shut down] a fairly competing business
14 instead of meeting the proper burden for a preliminary injunction to prevent infringement.” Dkt.
15 No. 20 at 12. As on the balance of equities, the Court agrees with Plaintiffs. “Where the moving
16 party has demonstrated a likelihood of success on patent invalidity, and likely irreparable harm
17 flowing from the inability to reach its customers on Amazon, the public interest favors
18 preventing a competitor from using a seemingly innocuous intellectual property rights-protection
19 notice to effectively shut down a competitor’s business.” *Medcursor*, 543 F. Supp. 3d at 880
20 (citing *Beyond Blond Prods.*, 479 F. Supp. 3d at 888).

21 Like in *Medcursor* and *Design Furnishings*, Amazon’s policies here shift the burden
22 from the claimed copyright holder, who normally bears the burden of proving infringement, to

23
24 ⁷ To the extent that the same is true of Plaintiffs’ injuries, *see supra* Section III.C (citing *Las Vegas Sands Corp.*,
360 F. Supp. 3d at 1080).

1 the alleged infringer. *Medcursor*, 543 F. Supp. 3d at 880; *Design Furnishings*, 2010 WL
2 5418893, at *8. Withholding a preliminary injunction would “allow anyone to effectively shut
3 down a competitor’s business . . . simply by filing numerous notices that the seller’s products
4 allegedly infringe on the complaining party’s copyright.” *Design Furnishings*, 2010 WL
5 5418893, at *8. Where, as here, Plaintiffs have shown that there are serious questions going to
6 the merits and a likelihood of irreparable harm, the public interest would be harmed absent
7 injunctive relief.

8 Therefore, the Court finds that the public interest factor weighs in favor of a TRO.

9 **F. Notice to Defendant**

10 The Court previously denied Plaintiffs’ motion for TRO because Plaintiffs failed to
11 demonstrate adequate notice to Defendant. Dkt. No. 17 at 4. Plaintiffs have now included a
12 certification in writing of their efforts to effect service. Dkt. No. 24 (Declaration of Adam E.
13 Urbanczyk); *see also* Dkt. Nos. 24-1–24-3 (exhibits showing emails to Defendant’s email
14 address identified in Amazon infringement complaints); Dkt. Nos. 7-2–7-5 (infringement
15 complaints).

16 Further, Plaintiffs argue that notice should not be required due to Defendant’s confused
17 identification of itself with respect to its Amazon infringement complaints, which do not include
18 any contact information other than Defendant’s email address. Dkt. No. 20 at 14. Plaintiffs allege
19 that this is “entirely deliberate” (*id.*), and the Court agrees. Like in *Rio Props., Inc. v. Rio Int’l*
20 *Interlink*, 284 F.3d 1007, 1018 (9th Cir. 2002), where the Ninth Circuit upheld the entry of
21 default judgment and found that service via email was “reasonably calculated . . . to apprise
22 [defendant] of the pendency of the action and afford it an opportunity to respond,” Defendant
23 here has structured its business such that it can only be contacted via its email address.
24 Defendant lists no easily discoverable street address in the United States or in China. Rather, it

1 designated only its email address as contact information in its Amazon complaints. *See* Dkt.
2 Nos. 7-2-7-5.

3 Plaintiffs have also provided sufficient evidence of immediate injury that will occur in
4 the absence of a TRO before Defendant can be provided notice. *See supra* Section III.C. The
5 impending destruction of Plaintiffs' inventories of tumbler cup lids, which are scheduled to be
6 destroyed by Amazon on June 20, 2025, is so immediate as to justify the issuance of a TRO
7 without notice. Dkt. Nos. 21-23; *see also Thomas v. Ocwen Loan Servicing, LLC*, No. C17-
8 1222, 2017 WL 8727862, at *3 (W.D. Wash. Aug. 22, 2017) (finding that foreclosure of
9 plaintiffs' home within three days was so immediate as to justify issuance of *ex parte* TRO).

10 Therefore, the Court finds that Plaintiffs have demonstrated that it is appropriate to issue
11 a TRO without written or oral notice to Defendant.

12 IV. CONCLUSION

13 Accordingly, Plaintiffs' motion for TRO is GRANTED IN PART and DENIED IN PART. The
14 Court ORDERS as follows:

- 15 1. Defendant is ORDERED to retract its patent infringement complaints based on the
16 '616 Patent on the Amazon.com platform, including Complaint IDs
17 17456741711, 17422703331, and 17473583681, by no later than **24 hours** from
18 the date of this Order;
- 19 2. Defendant, along with its officers, directors, employees, agents, subsidiaries,
20 attorneys, and all persons in active concert or participation with Defendant, is
21 hereby ENJOINED and RESTRAINED, pending a final disposition of the case or until
22 further Order of the Court, from issuing takedown notices concerning the
23 following Amazon Standard Identification Numbers ("ASINs") and products
24 therein, or otherwise notifying Amazon.com or other Third Party Platforms that
Defendant has patent rights being infringed by the following ASINs and products
therein offered for sale by Plaintiffs and/or that Plaintiffs' sales thereof violate
any patent rights: B0DSFVTB59, B0DSFSQ17X, B0DSFSMMT9,
B0DSFV2GBQ, B0DSFSP7DJ, B0DSFRWP1T, B0DSFS741X, B0DSFSJ1ZP,
B0DSFRHWP8, B0DSFQ2YJL, B0DSFS5QMB, B0DSFTZM6V,
B0DSFR2JLZ, B0DSFQ4HPJ, B0DSFR44S2, B0DSZXZH73, B0DSFTSZJS,
B0DSFRPY6B, B0DSFR258J, B0DSFR4V8X, B0DSFRM3J6, B0DSFRCHM9,
B0DSFS4D5M, B0DSFSW78G, B0DSFQ1BYX, B0DSFTWQC5,

1 B0DSFRGDDL, B0DSFSMRHM, and B0DSFRWP82, B0DT17L2SD,
2 B0DT151DK4, B0DT17229J, B0DT18B8WC, B0DT18XBV2, B0DT1B3MFX,
3 B0DT18BMMP, B0DS25STRT, B0DT174CTJ, B0DT16MMGZ, B0DT18FF94,
4 B0DSVWN96V, B0DSVTFXZ4, B0DS25BCDD, B0DSVWDFQ6,
5 B0DS24KNPG, B0DS26SYYG, B0DSVSM2MV, B0DSVTXJ2B,
6 B0DRFPDHRN, B0DJVK5PD4, B0DS289CXP, B0DRFM91MB,
7 B0DS25M5ZR, B0DRFN72G5, B0DSVT9R6B, B0DJVL2ZDW, B0DJVK8J8K,
8 B0DS25PB59, B0DJVKBCQY, B0DSVWCTX6, B0DSVTP6H9,
9 B0DS24MX9N, B0DRFNCLMH, B0DSVW1TP6, and B0DJVHBBZF,
10 B0DS1VC3CG, B0DS1TLXQT, B0DS1T9CHX, B0DS1VP1D4,
11 B0DS1V2YXX, B0DS1TF7GS, B0DS1VB3KQ, B0DS1SPV3C, B0DS1TQZNS,
12 B0DS1RQBV9, B0DS1SC62T, and B0DS1SZGDM;

- 13
- 14
- 15
- 16
- 17
- 18
- 19
- 20
- 21
- 22
- 23
- 24
3. Plaintiffs SHALL serve a copy of this Order on Defendant by email and file proof thereof with the Court within **three days** of the date of this Order;
 4. It is further ORDERED that the motion for temporary restraining order is converted to a motion for preliminary injunction;
 5. Defendant SHALL file a response to Plaintiffs' Motion for Preliminary Injunction by no later than **June 26, 2025, at 5:00 p.m.**, and Plaintiffs may file a reply by no later than **July 1, 2025, at 5:00 p.m.**;
 6. This Order SHALL expire on the date set below for hearing on the motion for preliminary injunction, unless extended for good cause;
 7. The matter of any bond SHALL be reserved until the hearing on the motion for preliminary injunction; and
 8. The Court SHALL hold a hearing on Plaintiffs' motion for preliminary injunction on **July 3, 2025, at 2:00 p.m.**, at which time Defendant will be asked to show cause why a preliminary injunction should not issue.

Dated this 19th day of June 2025.



Tana Lin
United States District Judge